

SHANGHAI SANJI DIE CASTING MACHINERY CO.,LTD

DC1600D PLATEN DIMENSION

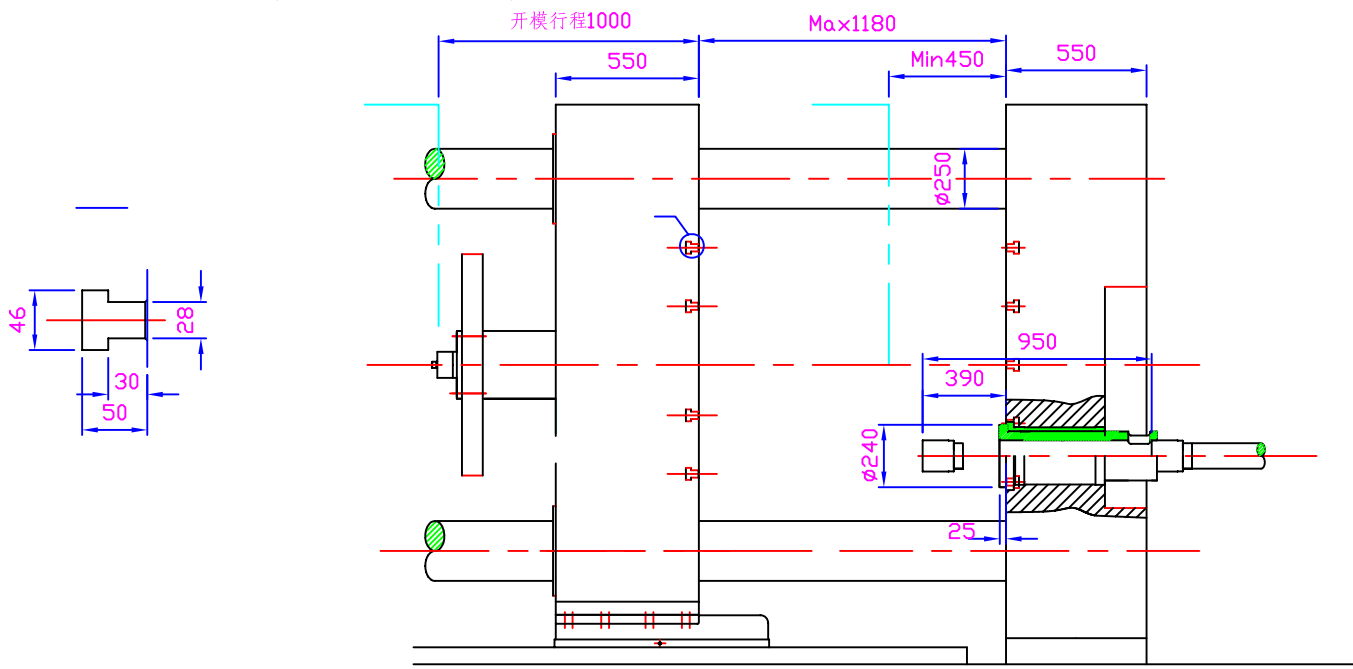

DC1600D OUTLINE DIMENSION

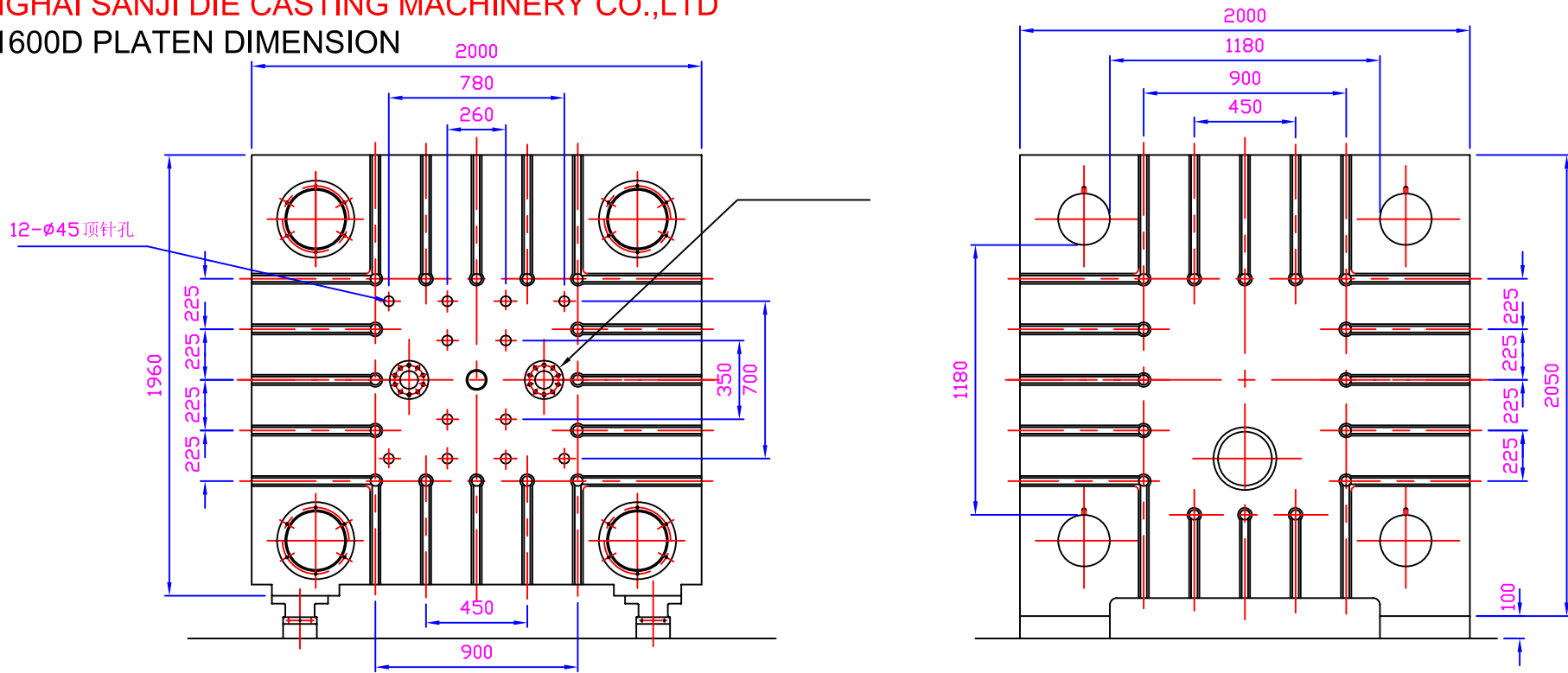
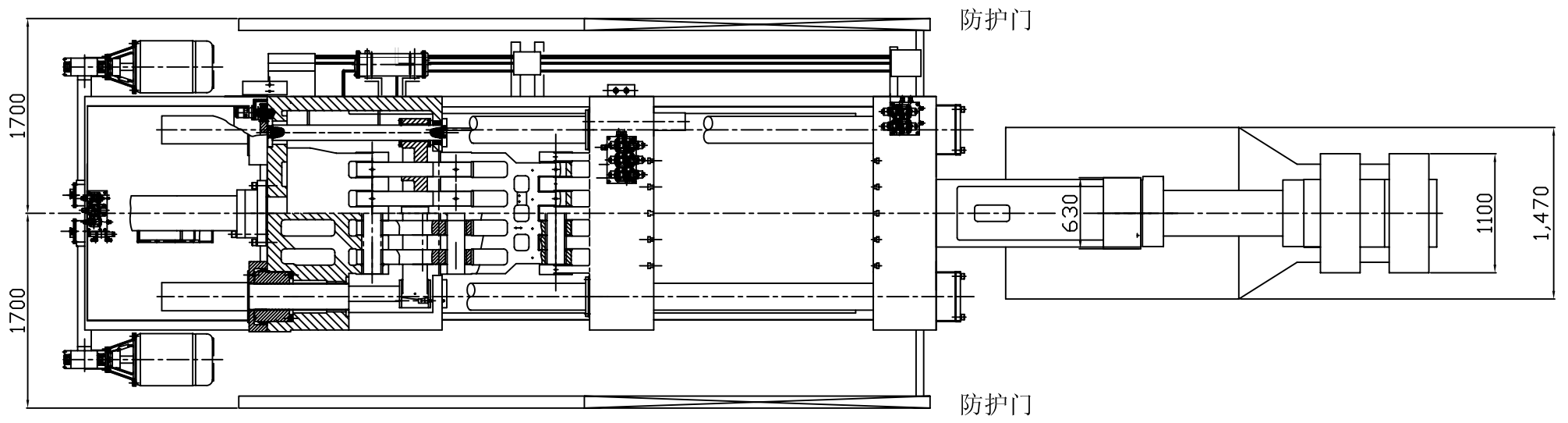
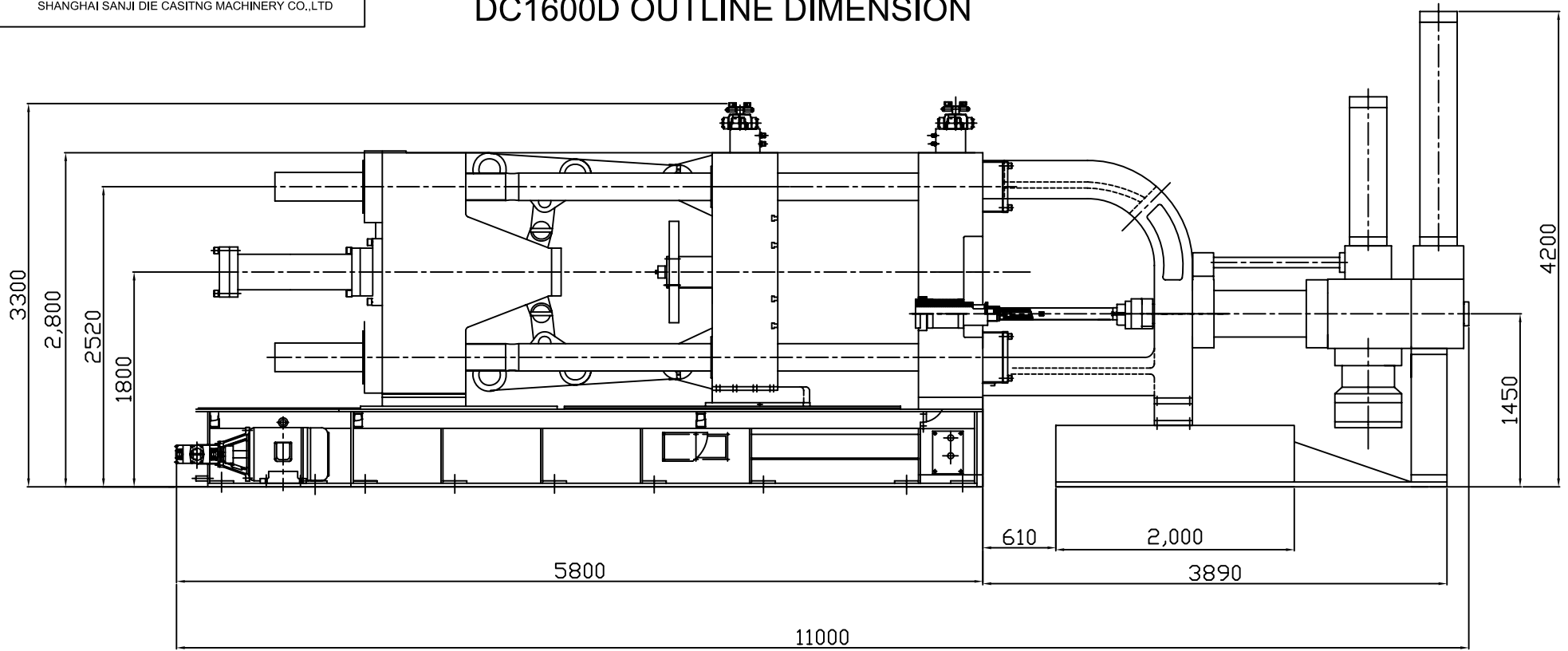

上海三基冷室压铸机主要技术参数表
SANJI COLD CHAMBER
DIE-CASTING MACHINE SPECIFICATIONS

项目 ITEMS	单位 UNIT	DC-1600D	
锁模部分 CLAMPING UNIT			
锁模力	CLAMPING FORCE	KN	16000
模板尺寸	Platen Size	mm	2000X2050
哥林柱间隔	Space between Tie Bar	mm	1180X1180
哥林柱直径	Tie Bar Diameter	mm	250
锁模行程	Die Stroke	mm	1000
模板厚薄距离	Die Height	mm	450-1180
射料部分 INJECTION UNIT			
射料力	Injection Force	KN	530-1250
跟踪距离	Plunger Tip Penetration	mm	390
射料位置	Shot Position	mm	-350
压射头直径	Standard Tip Diametre	mm	110,130,150
射料重量(铝)	Casting Weight	Kg	27
铸造压力	Injection Pressure	Mpa	56-126
铸造面积	Injection Area	cm2	1322-4066
顶出部分 EJECTION UNIT			
顶出压力	Ejection Force	KN	500
顶出行程	Ejection Stroke	mm	200
油泵与电机 Pump and Motor			
液压泵	Hydraulic Pump	2-Vame Pump (045-028) (60bar,140bar)	
电机	Electric Motor:		
1.液压泵电机	For Hydraulic Pump	2-37kw 380V	
2.调模电机	For Die Height Adjust	USE Hydralic Motor 用液压马达	
3.润滑电机	For Lub.Pump	2-20w 220V	
其它 OTHERS			
油箱容积	Tank Capacity	litre	2800
机身尺寸	Overall dimensions	(L x W x H)m	11 X 3 .5X 4.3
出机重量	Height of Machine	TON	102